



[www.dieci.com](http://www.dieci.com)

Dieci S.r.l. - Via E. Majorana, 2-4 - Montecchio Emilia (RE) ITALY  
Tel. +39 0522 869611 - Fax +39 0522 869798 - E-mail: [info@dieci.com](mailto:info@dieci.com)

**DIECI**



25.6

**MINI AGRI**

## PERFORMANCE

Maximum capacity (kg)	2.500
Maximum lifting height (m)	5,78
Maximum horizontal outreach (m)	3,25
Outreach at maximum height (m)	0,67
Fork swivelling angle	129°
Pull-out force (daN)	7.600
Towing force (daN)	4.400
Gradeability	40 %
Total weight empty (kg)	4.800
Max speed (km/h)	26 *

\* = referred to wheels with maximum admitted diameter

## BOOM

### Times: (in seconds)

Lifting	7,8
Descent	4,1
Extension	6,1
Retraction	3,4
Forward swivelling	3,5
Reverse swivelling	2,2

Patented compensation system

## HYDRAULIC PLANT

Gear pump with capacity at max. speed (lt/1')	80
Max operational pressure (bar):	230
Distributor control with joystick:	3 in 1

## DIFFERENTIAL AXLES

Steering axles: 2, with planetary reduction gears
Steering types: 4 wheels / transversal / 2 wheels
Front axle: rigid
Back axle: oscillating
Oil bath service braking on the front axle
Negative action parking brake.

## REFUELLING (Litres)

Hydraulic plant (total)	70
Fuel tank	80

## ENGINE

Model:	YANMAR
Maximum power kW (hp):	53,7 (73)
Revolutions per minute (rpm):	2500
Operation:	4 stroke diesel
Injection:	Electronic direct
Number and arrangement of cylinders:	4, vertical in line
Engine size (cm <sup>3</sup> ):	3319
Specific consumption at 2500 rpm (g/kWh):	254
Anti-pollution regulation:	Stage 3A

Turbo compressor

Liquid cooling system

## DEVICES AS PER STANDARD

Anti-tipping device with pejorative movement block.

Hydraulic socket for any accessories on the boom head.

Soundproof closed cab, ROPS-FOPS approved, with heater.

Self-blocking front axle differential (limited slip 45%).

## OPTIONALS AND ACCESSORIES

A/C; Digital speedometer; Water Heater; Driver's seat with pneumatic suspension; Light on boom head; Quick coupling for accessories; Radio; Anti-theft system; Glass protection.

(For additional customizations, contact the area dealer)

## TRANSMISSION

Hydrostatic transmission with variable flow pump.

Hydrostatic engine with automatic variation.

Electrical - hydraulic inversion.

Inching pedal for controlled advancement.

## TYPE-APPROVAL

Type-approval as a driving agricultural machine.

Machine is not suitable for towing trailers on public roads and roads for public use.

## TYRES

Tyres	12.5 - 18"
Alternative	12 - 16.5"

## DIMENSIONS

<b>A</b>	320
<b>B</b>	985
<b>C</b>	2350
<b>D</b>	765
<b>E</b>	3585
<b>F</b>	4100
<b>G</b>	860
<b>H</b>	1985
<b>I</b>	1500
<b>L</b>	1840
<b>M</b>	4540
<b>N</b>	1460
<b>O</b>	3555

Measurements expressed in millimetres

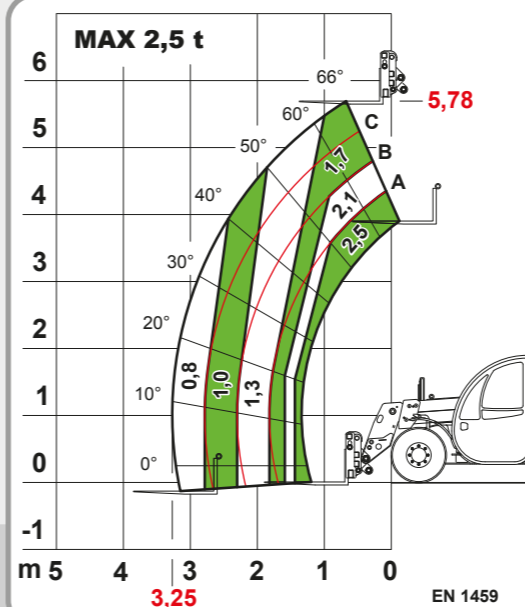
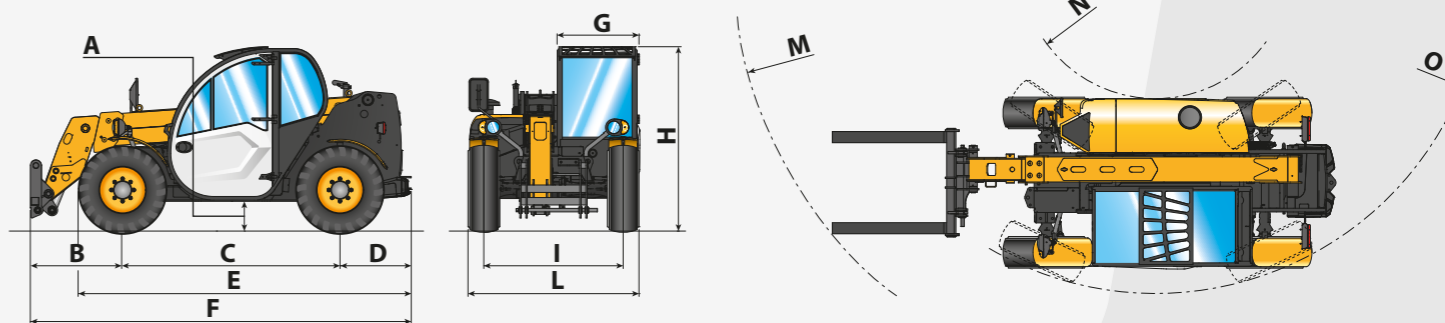

Mini Agri 25.6

EN 1459