

DIECI



PEGASUS



PEGASUS

Great stability and accuracy at extreme heights:
BETTER THAN A BOOM LIFT

In addition to the limits, maximum load capacity and outreach, CONTINUOUS ROTATION for an operational coverage of 1734.00 m²:
BETTER THAN A TELESCOPIC BOOM

Moving and lifting on wheels and outriggers, on level surface and off-road:
BETTER THAN A CRANE

ALL IN ONE BOOM LIFT TELESCOPIC BOOM CRANE



HANDLING

HI - TECHNOLOGY

EVOLUTION



PEGASUS

COMFORT



WIDE RANGE OF 6 MODELS

16 - 25 m
BOOM HEIGHT

3800 - 6000 Kg
MAX CAPACITY

2 VERSIONS
400° OR CONTINUOUS ROTATION

101 - 141 hp
2 ENGINE SIZES





101 hp
16 m
3800 kg
ROTATION
400°

101 hp
18 m
4000 kg
ROTATION
400°

141 hp
25 m
4000 kg
CONTINUOUS
ROTATION

141 hp
19 m
5000 kg
CONTINUOUS
ROTATION

141 hp
21 m
5000 kg
CONTINUOUS
ROTATION

141 hp
16 m
6000 kg
CONTINUOUS
ROTATION



Pegasus 38.16 400°

Pegasus 40.18 400°

Pegasus 40.25

Pegasus 50.19

Pegasus 50.21

Pegasus 60.16

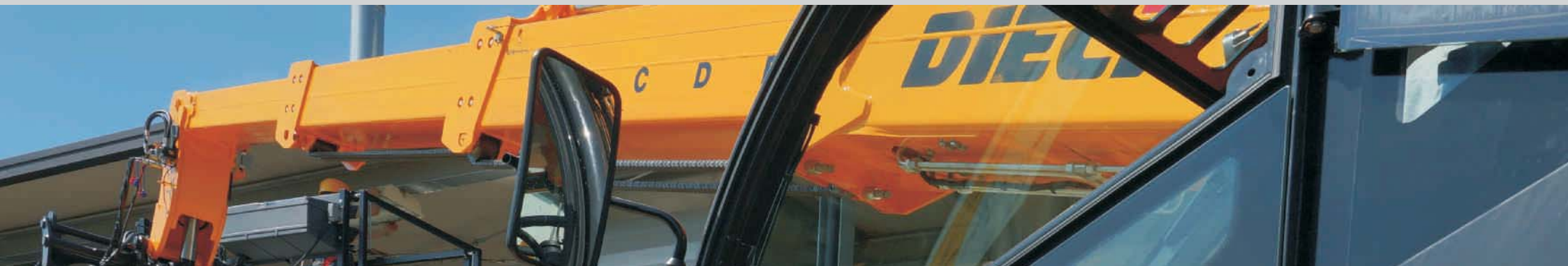

1734.00 m²
WORK AREA

EVOLUTION

ADAPTIVE
STABILIZATION

ANTI CRASH
SYSTEM

FULL
ELECTRONIC CONTROL

SELF LEVELING

PEGASUS





ON-BOARD COMPUTER

Advanced instrumentation with a large **color display** and intuitive icon-based interface, in order to provide more comprehensive and detailed information.

All machine functions are controlled with **CANBUS system** that allows a better response in real time.

SELF-LEVELING

Automatic leveling function with the simple push of a button on any type of land.

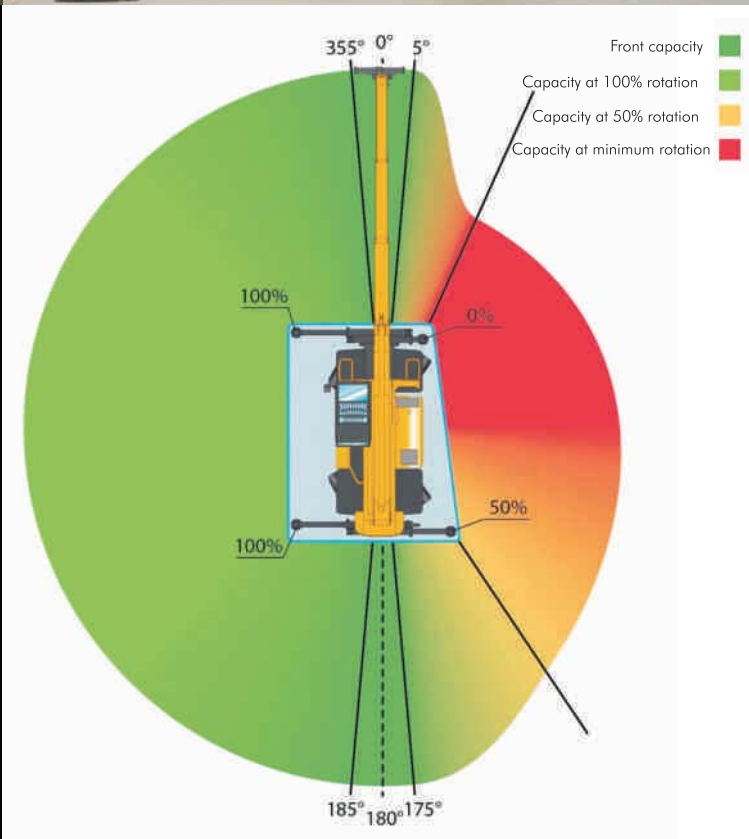

EASY WORK system

Automatic adaptation of the capacity diagrams based on the position of the outriggers, for an **operational coverage up to 1734 m²**.

The rotation and anti-tipping sensors allow to work safely in all configurations.

ANTI-CRASH system

Practical system that can set the operating limits in the work area in all directions.

Maximum safety for operators in the basket and absolute precise maneuvering without risk of collision with the structures.

All settings displayed in a **simple and intuitive** way on the LIMITS screen of the on-board computer.

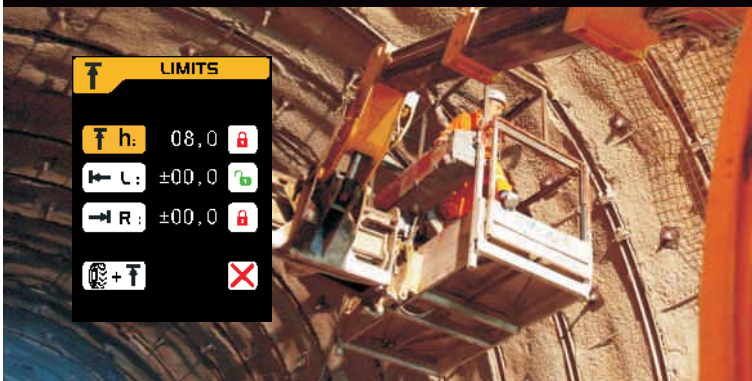

ON-BOARD
COMPUTER

COMFORT

VISIBILITY
360°

A/C

ROPS-FOPS





Absolute comfort

It's the first thing you feel aboard Pegasus DIECI. The meticulous study of the controls arrangement makes the machine use simple, easy and comfortable.

Unparalleled technology with the new **on-board computer**.

The display shows clearly and in real time all the information necessary to use the vehicle.

The **semi-automatic air conditioning system** with 7 ventilation grills allows perfect air circulation inside the cabin. Canopy and openable rear windows, standard on all models, allowing better ventilation while working.



Equipped with the **widest** door on the market, so accessing the driving position will be easier and safer.

Inside the cab everything has been designed in order to make work easier for the operator.

Soundproofing, **adjustable steering** wheel height and depth, storage compartments and various accessories such as **air conditioning**, radio, sunshade and pneumatic ergonomic seat allow to operate in conditions of total comfort.

The window wiper cleans the glass even at the top of the cabin for an unparalleled **360°** view.

The structural characteristics, meet the strict **ROPS/FOPS** safety requirements.



GREAT AGILITY

SELF
ALIGNMENT

REMOTE
CONTROL

INTERACTIVE
JOYSTICK

INCHING PEDAL

400°
CONTINUOUS ROTATION





INTERACTIVE JOYSTICK

ABSOLUTE PRECISION

The new joystick allows **full control** of the vehicle even with moving machine. For the most demanding it is possible to have the second manipulator as an option.

The compensated flow sharing distributor, allows **simultaneity of all movements**.

Double LED lighting:

Green for the capacitive deadman sensor and Red to control the outriggers.

The **Joystick** with **capacitive deadman sensor** and presence sensor in the seat prevent accidental operation.



SELF-ALIGNMENT

The high efficiency steering system transmits a smooth driving feeling both **on road** and **off road**.

Steering mode change facilitated by the **wheels self-aligning system**.

CONTINUOUS ROTATION

HIGH PRODUCTIVITY

A single setup with unlimited rotation for a total coverage up to 1734 m².

SERVING PEDAL

Essential control when the forward speed must be reduced or stopped, and the maximum hydraulic power is required for the equipment in use.

The **servo-assisted service brake** furthermore ensures safe and modulated braking reducing stress on the pedal.

REMOTE CONTROL

Ergonomic and lightweight, the remote control (optional) is equipped with a display for complete control of all machine functions.

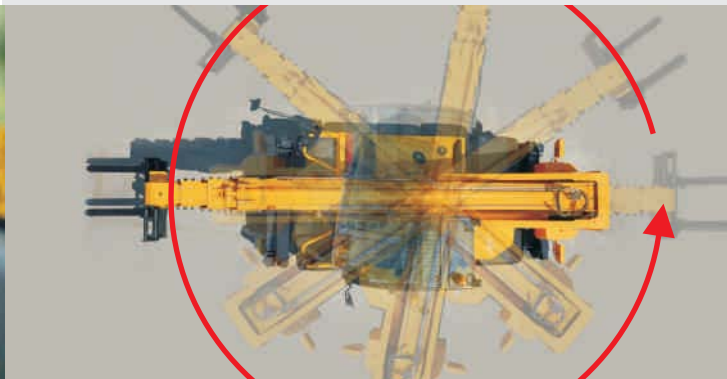

POWER

Stage 3B/Tier 4i

135 l/i'

HYDROSTATIC
TRANSMISSION

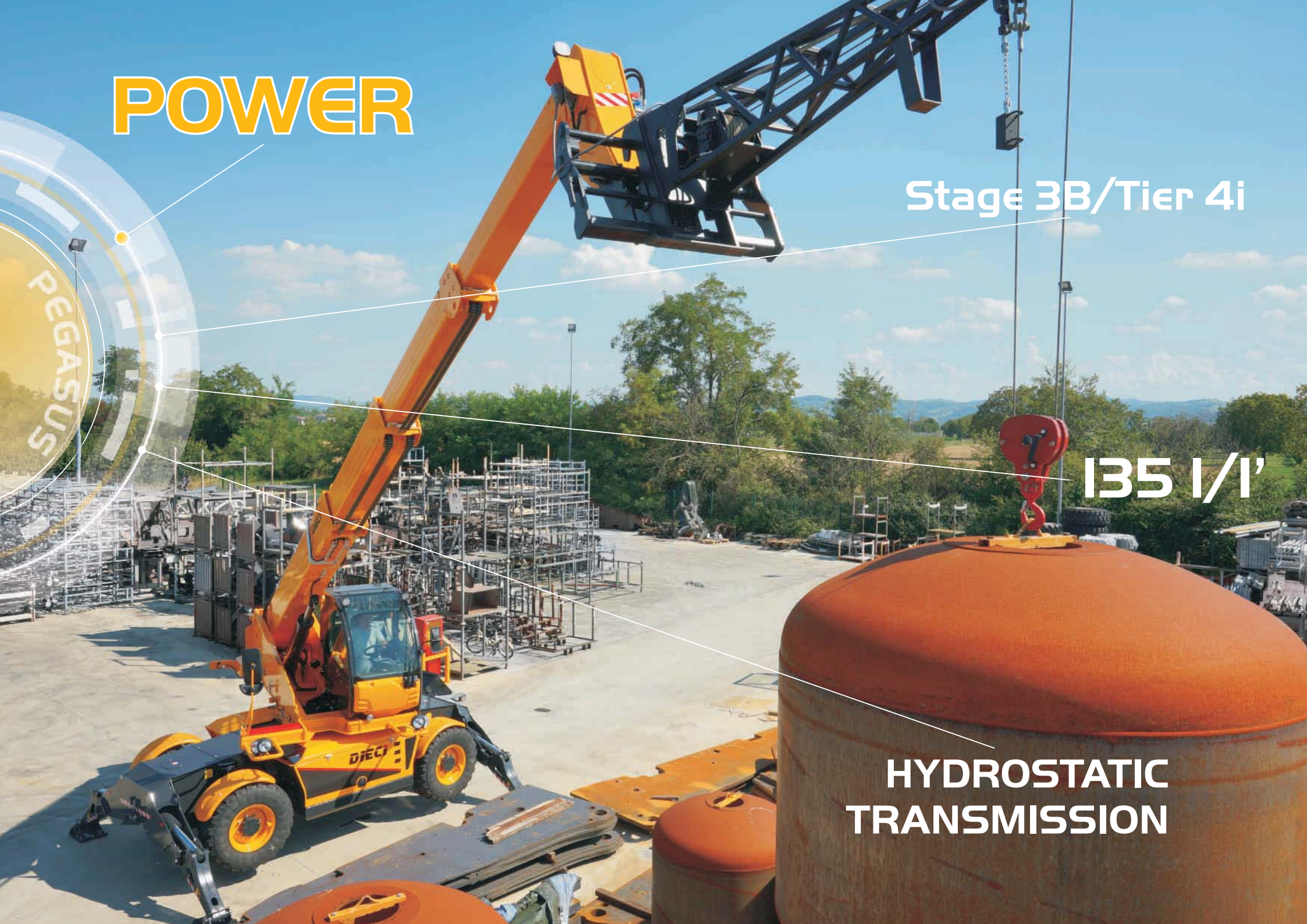



HYDRAULIC SYSTEM

New 135 l/1' hydraulic pump for greater speed of execution of the maneuvers, more sensitive and precise, high reliability; **20% processing times reduction.**

HYDROSTATIC TRANSMISSION

With the latest components, it facilitates the movement making them fluid and precise.

The engine electronic control provides **20% fuel saving and relative reduction of CO₂ emissions**, with almost total reduction of NO_x.



NEW ENGINES

All of which complying with the new emission regulations **Stage 3B/Tier 4i** are of the latest generation with fully electronic control and **fuel consumption reduced by more than 10%.**

DPF Diesel Particulate Filter Technology used on 400° models to take advantage of the 101 hp **KUBOTA** engine.

SCR with AdBlue

141 hp FPT engines, for the continuous rotation models, the SCR system with AdBlue for the treatment of exhaust gases, higher performance and further reduction of fuel consumption.



HI - TECHNOLOGY

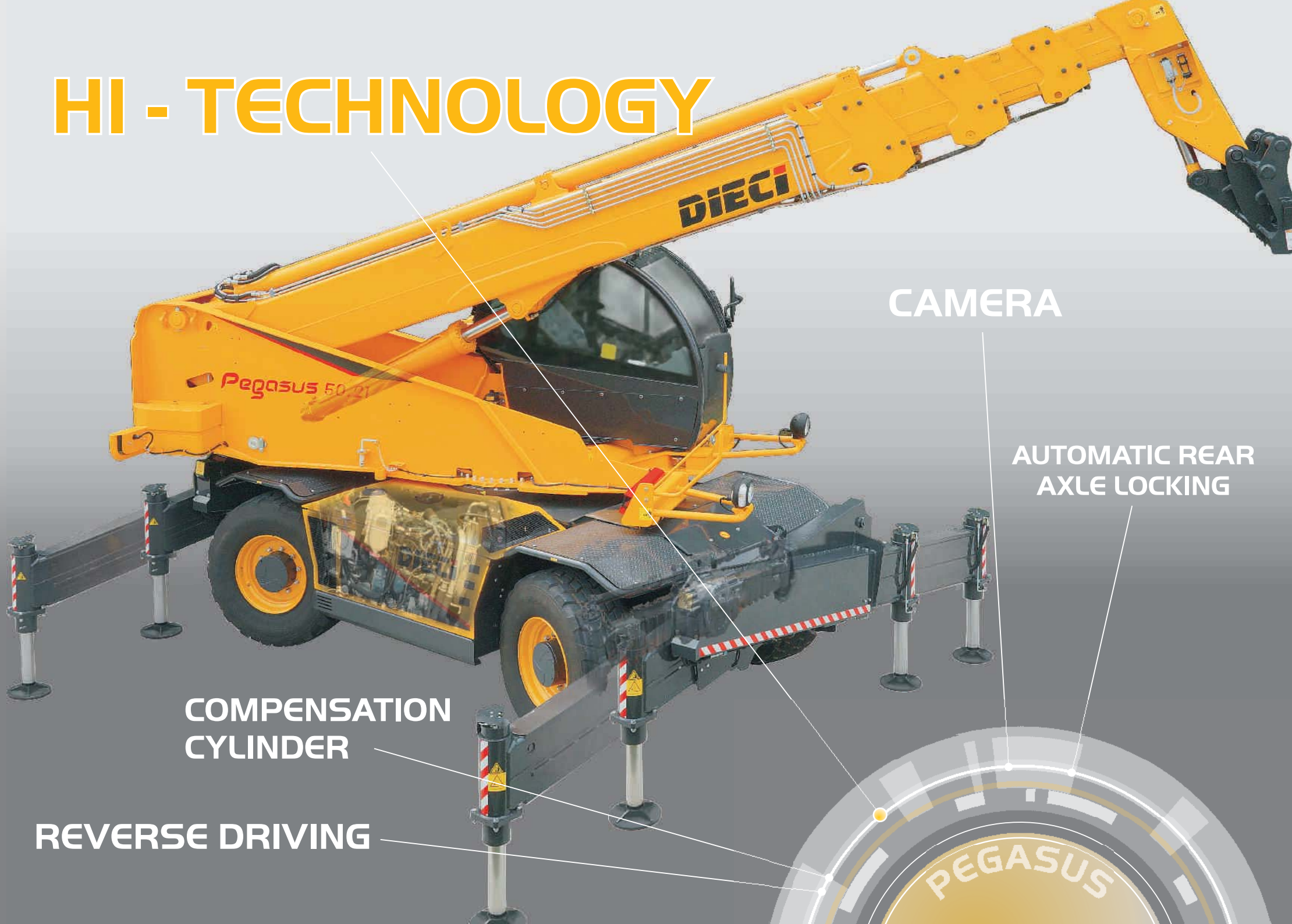

DIECI

Pegasus 5021

CAMERA

AUTOMATIC REAR
AXLE LOCKING

COMPENSATION
CYLINDER

REVERSE DRIVING

PEGASUS

DIECI PATENTED COMPENSATION CYLINDER

Located internally in the lifting cylinder it always makes the boom push balanced, increasing its durability over time.

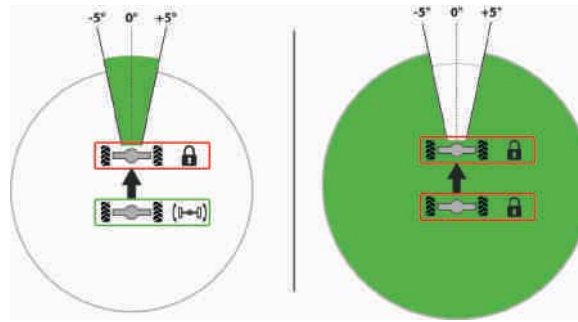

AXLE LOCKING

The rear axle oscillation is **automatically** locked when exceeding $\pm 5^\circ$ rotation in relation to the front position of the turret.

CAMERA MAXIMUM CONTROL

The cameras (optional) provide a millimetric view on the screen facilitating the load and movement operations.

180° REVERSE DRIVING

It is possible to drive with 180° rotated turret, **all the controls** including the axle locking **will be inverted automatically**.

DESIGN

It has always been a prerogative of DIECI machines but nothing is an end in itself.

Each restyling in addition to the aesthetics contributes to the cab comfort improvement and to engine cooling systems efficiency.

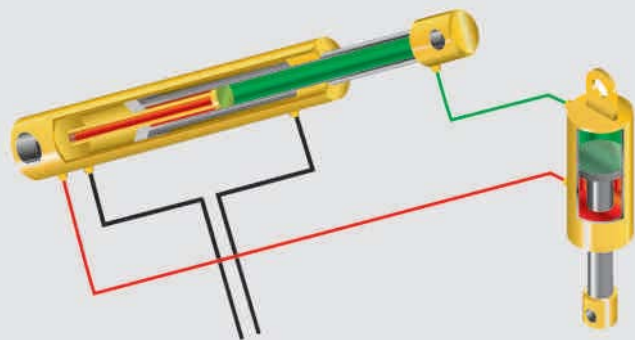

HI - TECHNOLOGY

SAFETY CELL

LOAD LIMITER

NEW CHASSIS

TRANSVERSE LEVELING

SOFT MOTION





Load limiter

Every Dieci machine is equipped with a control device that, in real time, analyzes the vehicle stability data and in the event that safety limits are reached it immediately stops the aggravating movements.

LEVELING

The **transverse leveling device** for inclination up to $\pm 10^\circ$, can operate in total peace of mind even on uneven ground.



SOFT MOTION

Maximum convenience and safety with the automatic boom movement speed reduction system, close to the physical limit or when the machine is in pre-alarm.

WATERTIGHT WIRING IP 67

Nothing is left to chance: in the most adverse working conditions **all wiring are watertight IP67**.

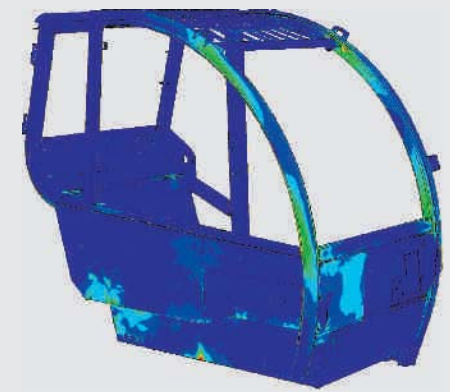

SAFETY CELL

ROPS-FOPS approved cab designed with safety cell to prevent deformation in the event of tipping or drop of heavy loads.

CHASSIS robustness

The chassis, with a strong visual impact, unmistakably characterizes Pegasus Dieci, the **robust** structure confers rigidity and total safety even under the most stressful conditions.

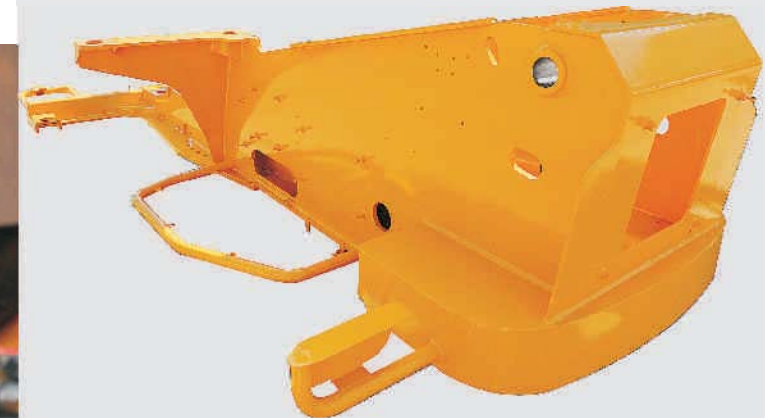

ALL IN ONE

TELESCOPIC BOOM

BUCKETS
FLOATING FORK CARRIER
FORKS
CONCRETE BUCKETS

CRANE

WINCHES
TRELLIS
REMOTE CONTROL

BOOM LIFT

MAN BASKET
FULL MOVE BOOM





TELESCOPIC BOOM

Maximum versatility in the use of **buckets** for handling aggregates, mixing buckets and for concrete. **Forks** for palletized loads and floating fork carrier. **Arch** centering gripper.

BOOM LIFT

Reaching distances up to **40 meters** with a single setup, maximum productivity with **extensible baskets** from 1.2 to 6.0 m and baskets installed on positive-negative boom.

CRANE

A **crane on wheels** where you need it. High capacity **winch and trellis** with winch for maximum distances.



MADE IN ITALY



FOR THE WORLD

DIECI, with more than half a century of experience and continuous development, achieves the **perfect vehicle** for every need.

The **Technical Assistance Service** is **present** across the world through an **extensive** network of authorized service centers and Dealers.

The automated spare parts warehouses and the direct assistance with the user, provide a very short time of intervention.

DIECI, within a few hours, can provide worldwide both spare parts and qualified staff.

Warranty

DIECI offers customized warranty extension packs for components and durability.



TECHNICAL

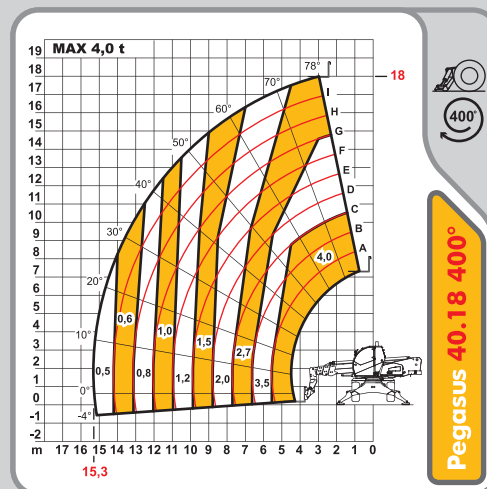
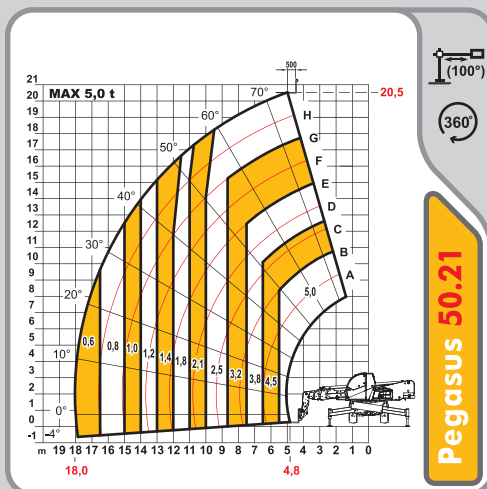
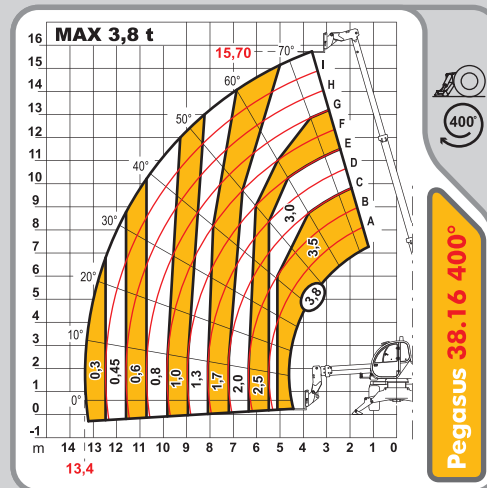
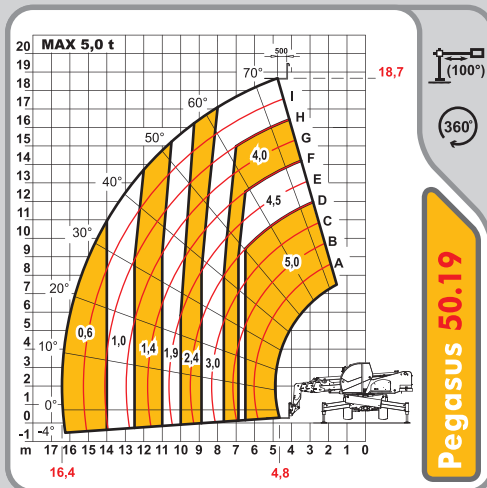
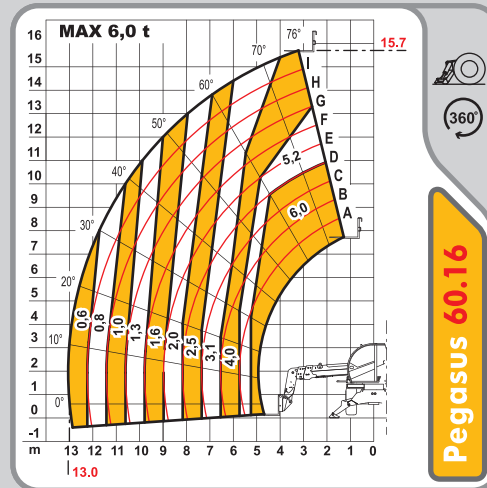
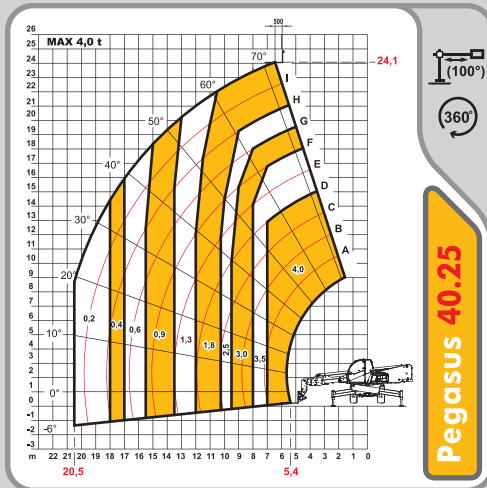

PERFORMANCE	40.25	50.19	50.21	60.16	38.16 400°	40.18 400°
Maximum capacity (kg)	4.000	5.000	5.000	6.000	3.800	4.000
Maximum lifting height (m)	24,10	18,70	20,50	15,70	15,70	18,00
Maximum horizontal outreach (m)	20,50	16,40	18,00	13,00	13,35	15,30
Outreach at maximum height (m)	6,45	4,80	5,50	3,20	3,70	2,95
Fork swiveling angle	115°	115°	115°	134°	134°	134°
Pull-out force (daN)	5.700	5.700	5.700	5.700	5.700	5.700
Towing force (daN)	9.400	9.400	9.400	9.000	7.300	7.300
Maximum climb angle	40%	40%	40%	40%	40%	40%
Total weight when empty (kg)	17.500	16.500	17.540	16.600	13.100	13.600
Maximum speed (km/h)	40*	40*	40*	40*	30*	30*

* referred to wheels having the maximum allowable diameter

BOOM	40.25	50.19	50.21	60.16	38.16 400°	40.18 400°
Times: empty (seconds)						
Lifting	21,9	21,9	21,9	24,8	17,4	20,6
Descent	13,8	13,8	13,8	16,5	12,6	14,2
Extension	44,4	27,8	31,2	24,7	34,2	26,0
Retraction	23,1	16,9	17,4	11,6	21,9	17,0
Forward swiveling	3,7	3,7	3,7	5,7	3,9	3,8
Reverse swiveling	2,3	2,3	2,3	2,5	2,4	2,0

Patented compensation system

ENGINE	40.25 / 50.19 / 50.21 / 60.16
Model	FPT
Nominal power at 2200 rpm kW (hp)	96 (130)
Peak power at 1900 rpm kW (hp)	105 (141)
Revolutions per minute (rpm)	2200
Operation	4-stroke Diesel
Injection	Electronic Direct, Common Rail
Number and arrangement of cylinders	4, vertical in line
Displacement (cm3)	4500
Specific consumption at 1900 rpm (g/kWh)	208
Emission standards	Stage 3B/Tier 4i
Aftercooler turbo compressor / Liquid cooling system	

ENGINE	38.16 400°	40.18 400°
Model	Kubota	
Maximum power kW (hp)	74.5 (101)	
Revolutions per minute (rpm)	2600	
Operation	4-stroke Diesel	
Injection	Electronic Direct, Common Rail	
Number and arrangement of cylinders	4, vertical in line	
Displacement (cm3)	3769	
Specific consumption at 2600 rpm (g/kWh)	231	
After-treatment exhaust gas system	DPF (Stage 3B/Tier 4i)	
Aftercooler turbo compressor / Liquid cooling system		

OPTIONAL AND ACCESSORIES

- A/C
 - Tachometer
 - Water Heaters
 - Seat pneumatic suspension
 - Light on the boom head
 - Quick coupling for accessories
 - Radio
 - Anti-theft system
 - Window protection
 - Transverse leveling on wheels and other...
- (for further customizations, contact your local dealer).

TRANSMISSION

- Hydrostatic transmission with variable displacement pump
- Hydrostatic engine with automatic adjustment
- Electro-hydraulic reversing
- Inching pedal for controlled forward movement
- Servocontrolled 2-speed gearbox

SPECIFICATIONS

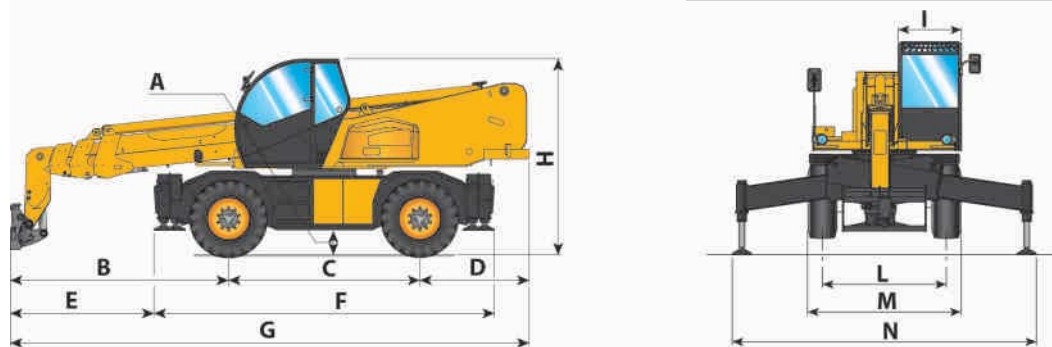

40.25
50.19
50.21

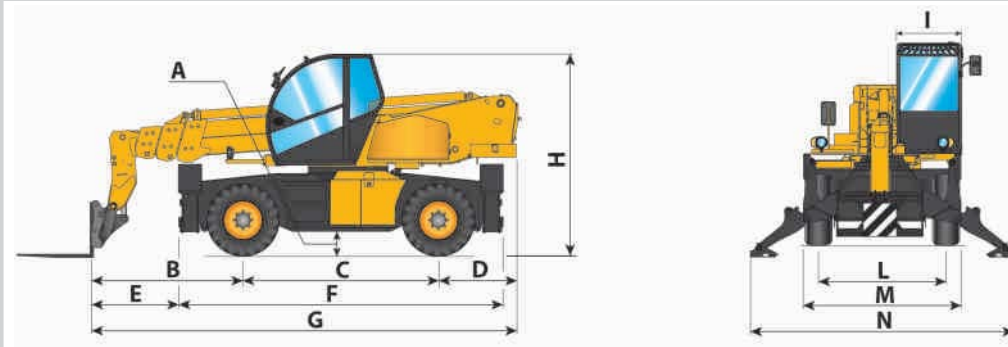
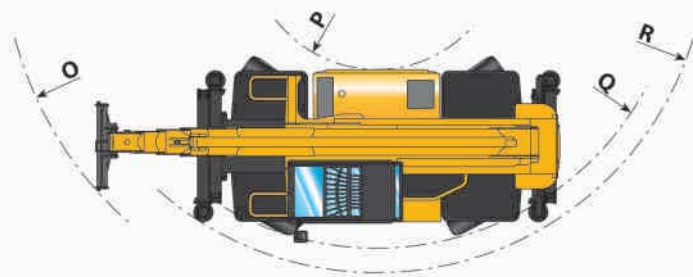

60.16
38.16 400°
40.18 400°

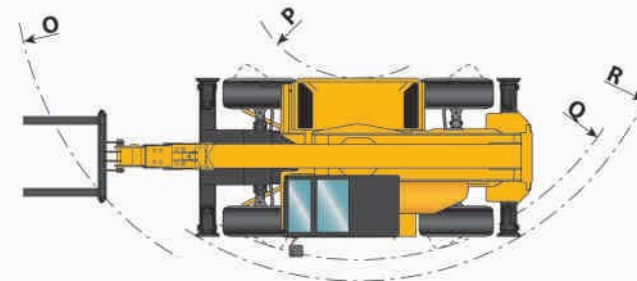

HYDRAULIC SYSTEM

Double gear pump with "Energy Saving" system	
Max speed capacity (Lt/1)	135
Max operating pressure (bar)	230
Distributor control with joystick	5 in 1 proportional
Simultaneous movements	5
"Load Sensing" proportional distributor with "Flow Sharing"	

DIFFERENTIAL AXLES

Steering axles: 2 with planetary reduction gears	
Type of steering: 4 wheels / transversal / 2 wheels	
Front axle: leveling 360° / rigid 400°	
Rear axle: oscillating	
Service braking with oil bath on the 4 wheels with double hydraulic system and servo brake	
Negative action parking brake	

REFUELING (liters)

Hydraulic system (total)	270
Diesel tank	180

SAFETY DEVICE

Movement stopping in case of overload, starting only with gear in neutral, running only with driver on board, automatic parking brake with the engine off.
Automatic transversal leveling with stabilizers.
Outriggers locking and leveling with raised boom.

STANDARD DEVICES

ROPS - FOPS approval, suspension on silent-blocks, soundproofing, ventilation and heating, roof and openable rear glass, double-glaze door with top opening, adjustable seat with safety seatbelt, radio pre-arrangement, adjustable steering wheel.	
Monitor TFT3" with load indicator and diagnostic functions, tachometer analog gages, coolant temperature and fuel level.	
Turret rotation maximum speed adjustment.	

TIRES

	40.25 / 50.19	38.16 - 400°
	50.21 / 60.16	40.18 - 400°
Tires	18R22.5"	405/70R20"
Alternative	18-22.5"	405/70-20"

DIMENSIONS

DIMENSIONS	40.25	50.19	50.21	60.16	38.16 400°	40.18 400°
A	360	360	360	360	310	310
B	3365	2660	2835	2580	2430	2280
C	2950	2950	2950	2950	2950	2950
D	1685	1150	1365	1190	1175	1175
E	2195	1510	1665	1580	1490	1330
F	5290	5290	5290	4940	4880	4880
G	8000	6760	7150	6720	6555	6405
H	3025	3025	3025	3020	3035	3035
I	980	980	980	980	980	980
L	1920	1920	1920	1920	1920	1920
M	2380	2380	2380	2380	2380	2380
N	5070	4800	5070	3820	3970	3970
O	6175	5450	5585	5380	5265	5160
P	1700	1700	1700	1700	1700	1700
Q	4430	4430	4430	4430	4430	4430
R	4790	4790	4790	4800	4750	4750

dimensions in millimeters

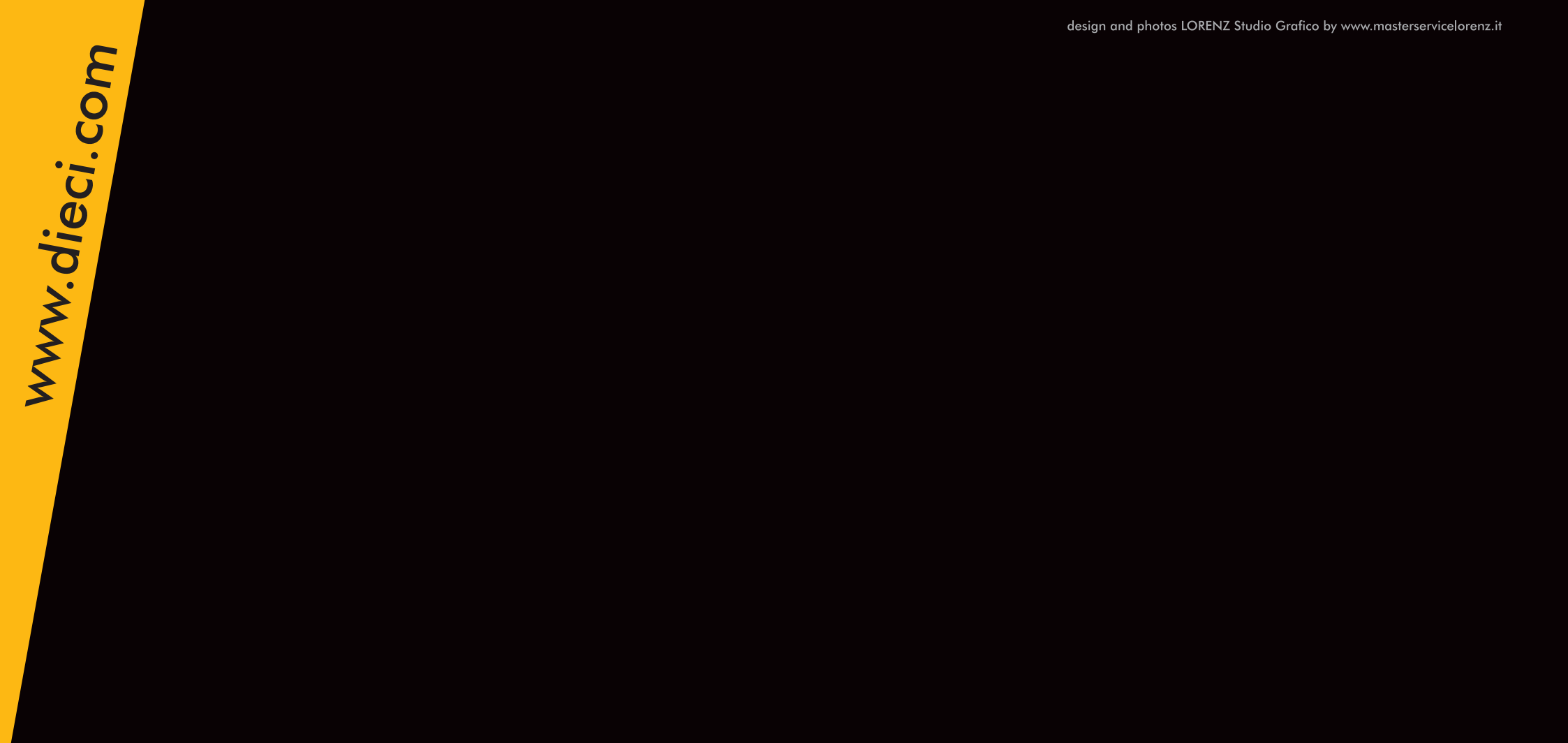

www.dieci.com

