

PSC 6025

ELECTRIC | HYDRAULIC SERVICE CRANE

PALFINGER

LIFETIME EXCELLENCE

SUPERIOR LIFTING SYSTEM



DISCLOSURE: Image does not show the standard shipping package.

STANDARD FEATURES

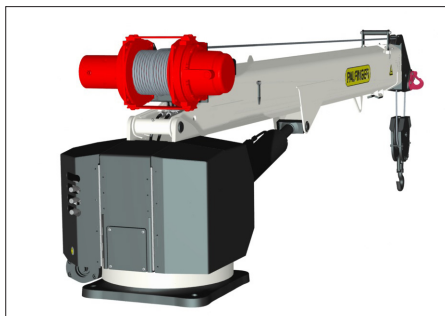

WINCH

Planetary winch for speed and durability. Boom mounted winch for consistent line length when raising or lowering boom.



HORSE HEAD

No bail and limit switch to interfere in operation, low profile design, and optional boom tip hook.



LOAD BLOCK STOWING BRACKET

Bracket and pads designed to keep load block from contacting the boom when stowed.

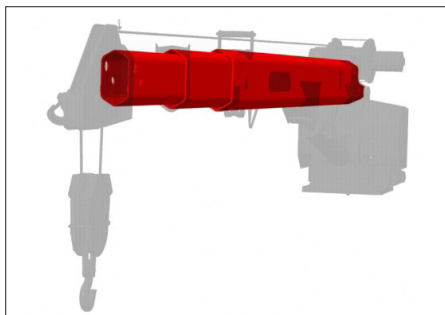

HEXAGONAL BOOMS

Maintenance free high tensile strength self-centering single weld boom sections powered by internal extension cylinders.

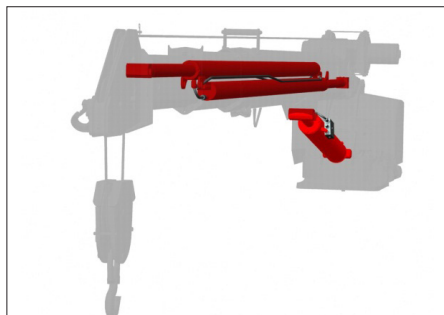

CYLINDERS

All cylinders are e-coated and use a 5 stage marine grade seal system, exceeding ANSI B30.5.

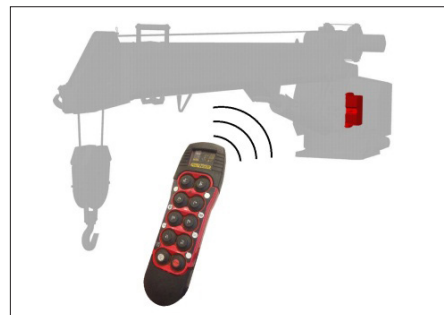

WIRELESS REMOTE

Push button style proportional wireless remote control, standard.



IWC - INTELLIGENT WINCH CONSOLE

Two Block Damage Prevention System is integrated into winch mounting platform eliminating the need for boom tip apparatus and cord reel. Complies with ANSI B30.5

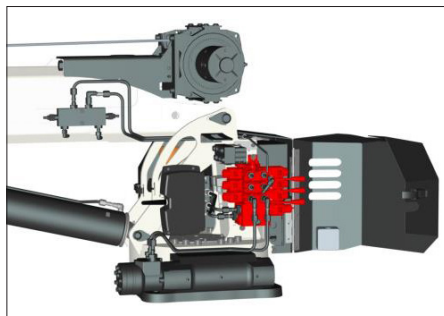

PROPORTIONAL CONTROL

Through the control valve proportional control is standard on all E/H and Hydraulic models.



3 YEAR WARRANTY

Industry leading 3 year warranty on structural components.

OPTIONS



OVERLOAD CAPACITY WARNING

105 db audible warning at 90% of load capacity and at overload condition, exceeding ANSI B30.5.

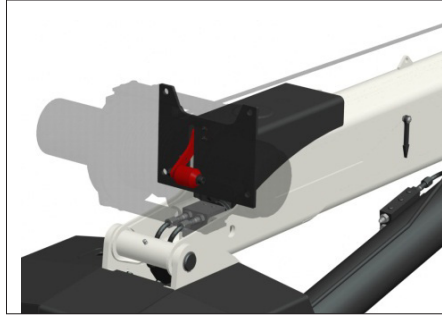

THIRD WRAP LIMITING SYSTEM

Integrated system prevents wire rope spool off, ensuring three wraps remain on drum, exceeding ANSI B30.5.



BOOM TIP HOOK

1.5 ton capacity boom tip hook, horsehead has threaded weldment for mounting.

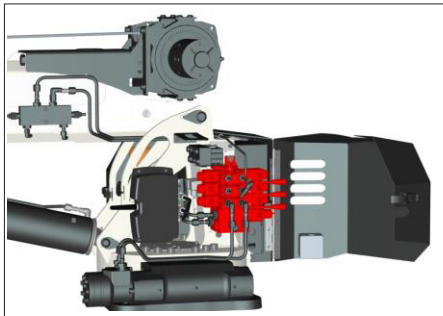

PROPORTIONAL CONTROL VALVE

Fully proportional control valve enables operation of multiple functions simultaneously at independent speeds. Only available on hydraulic models.



REMOTE CONTROL STOWING BRACKET

Steel stowing bracket for radio remote control can be mounted in the chassis or in the work truck body.

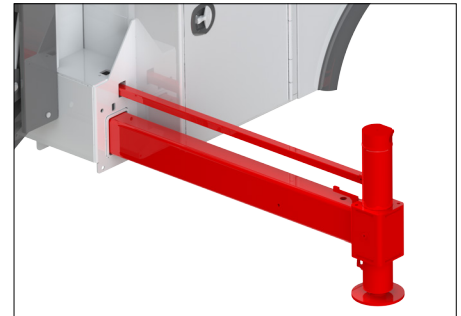

OUTRIGGERS

Outriggers may be required to comply with OSHA 1910.180.

E-COAT PROTECTION



MEDIA BLAST

A high quality exterior protection that removes any surface imperfections and provides an optimized surface for E-Coating.



E-COAT

Efficient, environment-friendly and recyclable paint is applied with a precise thickness over the entire product to ensure superior corrosion protection.

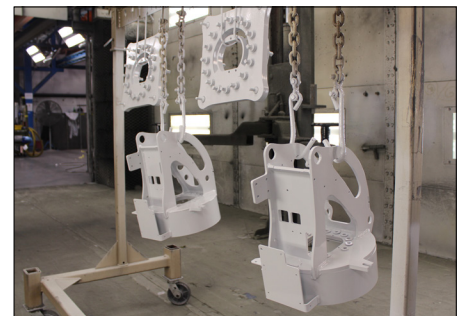

TOP COAT

For all non-black crane components, a top coat polish is applied to certify maximum durability and finish.



SUPERIOR REACH AND LIFT

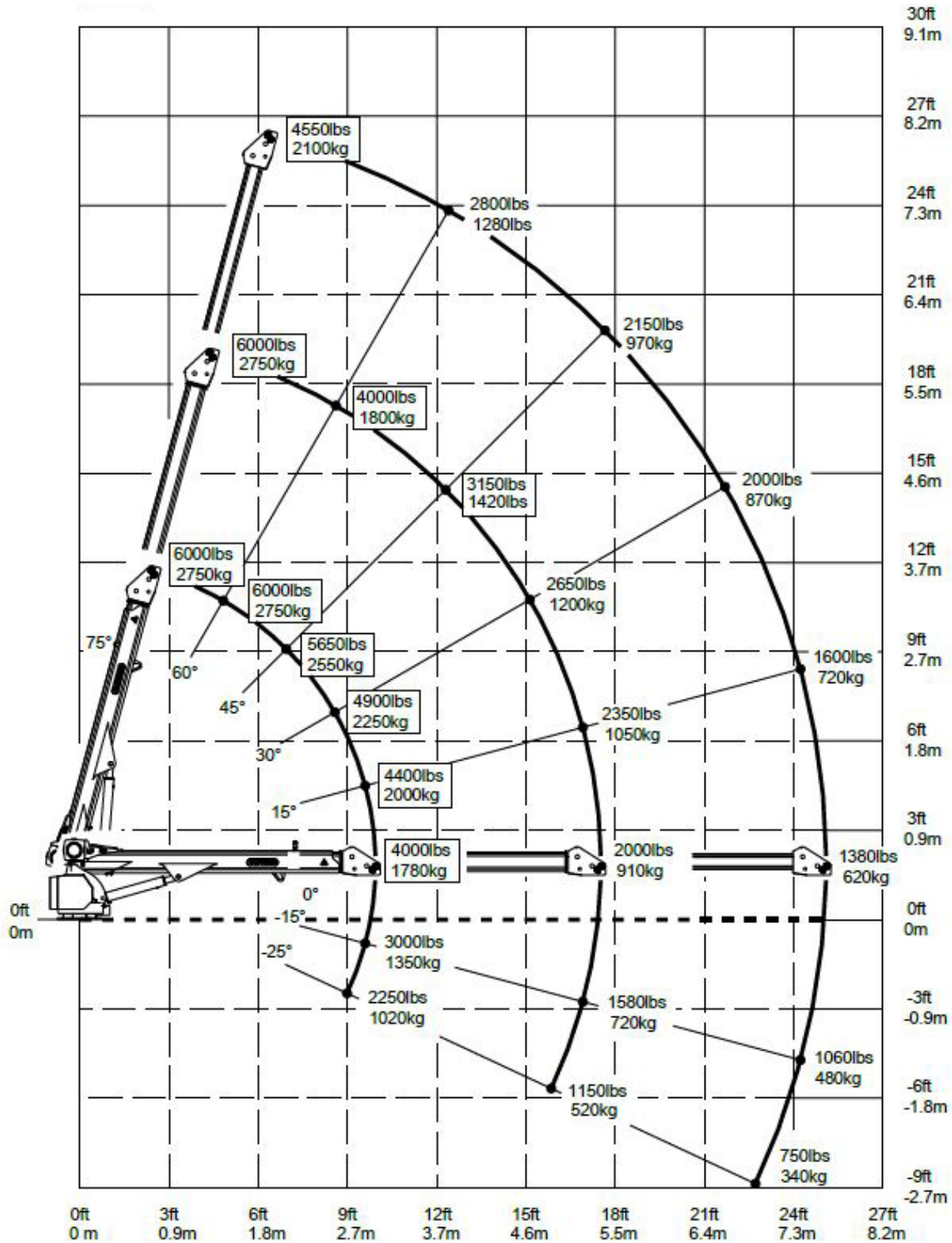

Weights of load-handling devices are part of the load lifted and must be deducted from the capacity.

....lbs
....kg

Boxes denote two-part line required.

TECHNICAL SPECIFICATIONS

CRANE RATING

Rated lifting moment	38,500 ft. lbs. (52.2 kNm (5.3 mt))
Maximum lifting moment	43,730 ft. lbs. (66.5 kNm (5.9 mt))
Hydraulic outreach	25.0 ft. (7.6 m)
Crane weight Electric	1,280 lbs. (580 kg)
Crane weight Hydraulic	1,230 lbs. (560 kg)
Hydraulically powered extensions	

CONTROL SYSTEM

Wireless remote control unit
Integrated E-stop button
Manual valve activation capability
Integrated warning horn
12V DC power supply

ROTATION SYSTEM

Slewing torque	5,545 ft. lbs. (7.5 kNm (0.8 mt))
Slewing angle Electric	Continuous rotation
Slewing angle Hydraulic	410° rotation

STANDARDS (meets or exceeds)

Crane	ANSI B30.5	OSHA 1910.28
Calculation	EN 12999 H1,B6	

PLANETARY GEAR WINCH

Max. winch force single line	3,000 lbs. (1,425 kg)
Max. winch force double line	6,000 lbs. (2,750 kg)
Max. line speed	28 ft./min (8.5 m/min)
Galvanized aircraft cable	95' x 5/16" (28.9 m x 7.9 mm)
Two-block damage prevention system	
3rd wrap end stop system option	

HYDRAULIC SYSTEM

Operating pressure	2,800 psi (19.3 Mpa (193 bar))
Required oil flow Hydraulic	5.2 GPM (20.0 L/min)
Electronic overload protection system	
Marine grade 5 seal system on all cylinders	
Non integrated load-holding valves on all cylinders	

CRANE | CHASSIS INTERFACE

Base plate dimension	17.75" x 17.75" (450 mm x 450 mm)
Hole pattern	14.75" x 14.75" (375 mm x 375 mm)
Mounting bolts	4 x 1" -8 UNC

CHASSIS RECOMMENDATION

Chassis style	Conventional
Recommended GVWR	Class 4 (14,001 lbs. (6,350 kg))

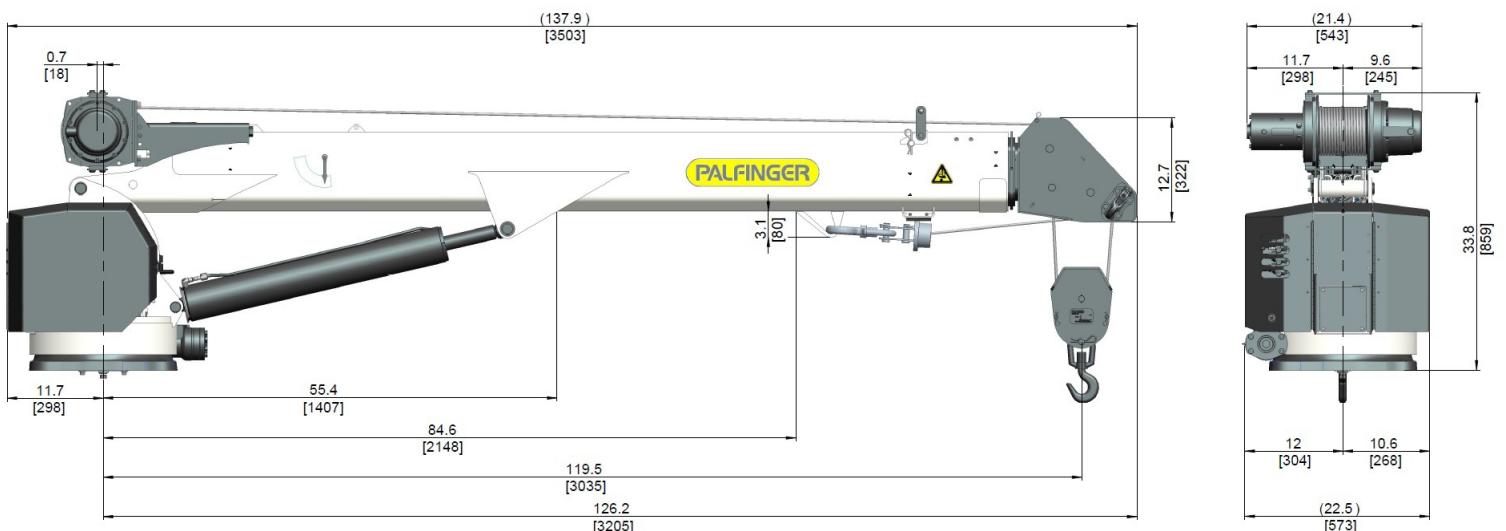



Omaha Standard PALFINGER LLC
 3501 S. 11th Street
 COUNCIL BLUFFS, IA 51501
 T. 1-800-279-2201
 F. 1-712-328-8383

WWW.PALFINGER.COM

PALFINGER Service Crane - Product Range

	PSC 3216	PSC 4016	PSC 4025	PSC 5025	PSC6025	PSC 4329	PSC 6229	PSC 7229	PSC 8629
Rated Lifting Moment	12,500 ft. lbs. (17kNm (1.7mt))	18,500 ft. lbs. (25.1kNm (2.6mt))	18,500 ft. lbs. (25.1kNm (2.6mt))	32,500 ft. lbs. (44.2kNm (4.5mt))	38,500 ft. lbs. (52.2kNm (5.3mt))	43,000 ft. lbs. (58.3kNm (5.9mt))	62,000 ft. lbs. (84.1kNm (8.6mt))	72,000 ft. lbs. (97.6kNm (10mt))	86,000 ft. lbs. (116.6kNm (11.9mt))
Max Lifting Moment	14,560 ft. lbs. (19.6kNm (2.0mt))	23,235 ft. lbs. (31.4kNm (3.2mt))	20,585 ft. lbs. (27.9kNm (2.9mt))	34,580 ft. lbs. (49.3kNm (5.0mt))	43,730 ft. lbs. (58.0kNm (5.9mt))	49,180 ft. lbs. (66.5kNm (6.8mt))	68,900 ft. lbs. (93.2kNm (9.5mt))	79,450 ft. lbs. (107.7kNm (11mt))	94,676 ft. lbs. (128.4kNm (13mt))
Capacity	4,000 lbs. (1814kg)	4,000 lbs. (1814kg)	4,000 lbs. (1814kg)	5,000 lbs. (2286kg)	6,000 lbs. (2750kg)	8,000 lbs. (3650kg)	10,800 lbs. (4900kg)	12,500 lbs. (5700kg)	14,000 lbs. (6400kg)
Boom Extension	1 Hydraulic + 1Manual (2 HydraulicOption)	1 Hydraulic + 1Manual (2 Hydraulic Option)	2 Hydraulic	2 Hydraulic	2 Hydraulic	2 Hydraulic	2 Hydraulic	2 Hydraulic	2 Hydraulic
Power Outreach	11.4ft (16ft) 3.5m (4.9m)	11.4ft (16ft) 3.5m (4.9m)	25 ft (7.6m)	25 ft (7.6m)	25 ft (7.6m)	29.1 ft (8.9m)	29.1 ft (8.9m)	29.1 ft (8.9m)	29.1 ft (8.9m)
Winch Speed	19.6ft/min (6.0m/min)	19.6ft/min (6.0m/min)	19.6ft/min (6.0m/min)	18.8ft/min (5.7m/min)	28.0ft/min (8.5m/min)	60ft/min (18.2m/min)	60ft/min (18.2m/min)	60ft/min (18.2m/min)	60ft/min (18.2m/min)
Standard Weight	650 lbs. (295kg)	650 lbs. (295kg)	1010 lbs. (458kg)	1170 lbs. (530kg)	1280 lbs. (580kg)	2149 lbs. (975kg)	2407 lbs. (1092kg)	2731 lbs. (1239kg)	2833 lbs. (1285kg)
Control System	Radio Remote Control	Radio Remote Control	Radio Remote Control	Radio Remote Control	Radio Remote Control	Radio Remote Control	Radio Remote Control	Radio Remote Control	Radio Remote Control
Chassis Specifications (Min.Recommended GVWR)	Class 3 10,001 lbs. (4,540kg)	Class 3 10,001 lbs. (4,540kg)	Class 3 10,001 lbs. (4,540kg)	Class 4 14,001 lbs. (6,350kg)	Class 4 14,001 lbs. (6,350kg)	Class 5 19,000 lbs. (8,620kg)	Class 6 25,000 lbs. (11,340kg)	Class 6 25,000 lbs. (11,340kg)	Class 7 33,000 lbs. (14,970kg)



Download the PALFINGER Mobile App for more information about PALFINGER products in North America!

