

DT 03 / RST 0303

Double Ballast Tamper

Using a Double Ballast Tamper DT 03 with 2x 60° rotation or a RST 0303 (which is mounted for example to a tiltrotator), the packing of ballast under sleepers is not only fast, but also highly efficient and economical – ideal for road-rail excavators with 14 up to 22 t or 24t / 30800 lbs up to 48400 lbs or 52800 lbs operating weight.



- **Complete** with two high frequency vibrating units.
- **Efficiency:** The strong, silent compressors destabilise the gravel ballast, while their built-in vibration units are running. Their four arms are thrust into the gravel and pack it by vibrating. They move alongside and below the sleeper into the ground and tamper optimally.
- **Flexibility:** adjustable arms and force.
- **High and flexible frequency.**
- **Low noise operation.**
- **Strong vibration rubbers** for low vibration against the machine.
- **Adjustable tamping depth.**
- **Different displacements** of engines available according to the pump capacity needed.

Double Ballast Tamper DT 03 / RST 0303

Type	Gripping range A (mm / in)	Weight (w/o top adapter) (approx. kg / lbs)	Length E (mm / in)	Height C (w/o adapter) (mm / in)	Width (mm / in)	Gripper elements (pieces)	Compaction force (kg / lbs)	Operating weight (t / lbs)
DT 03	195 - 650 / 7.83 - 25.59	1405 / 3091	2200 / 86.62	1310 / 57.09	860 / 33.85	2 x 4	7500 / 16500	14 - 22 / 30800 - 48400
RST 0303	195 - 650 / 7.83 - 25.59	1830 / 4026	2250 / 88.58	1600 / 62.99	870 / 34.25	2 x 4	7500 / 16500	14 - 24 / 30800 - 52800

Package consists of: DT 03: adapter for parallel mounting, two RST 03 ballast tamper, KM 15 F273/273 rotator, optional upper bracket;
RST 0303: adapter ADP0303 for parallel mounting of 2x RST03, two RST 03 ballast tamper, 2 mechanical or (optionally) hydraulic quick hitches

Note: fitting to all kinds of rails. Other upper brackets available.

Requirements of Excavator

Two hydraulic circuits needed, one of them double effective (open / close) and one hammer line (vibration) with free line to the tank

Operating pressure: max. 20 MPa (200 bar) / 2880 psi

Pump capacity: 40 - 130 l/min / 10.57 - 34.35 GPM (free line to tank required)

Different couplings available. Available without upper bracket too.

Technical Drawings – Example of Use

DT 03
with 2x 60° Rotation
beneath the (optional)
upper bracket and two
RST 03 attachments

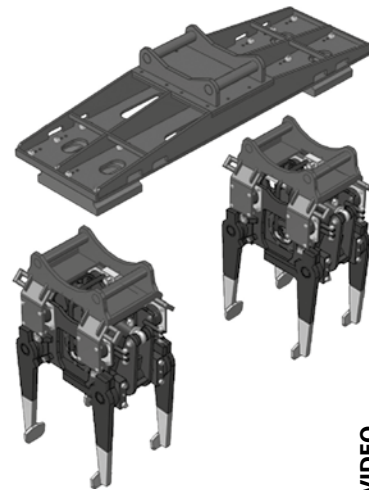
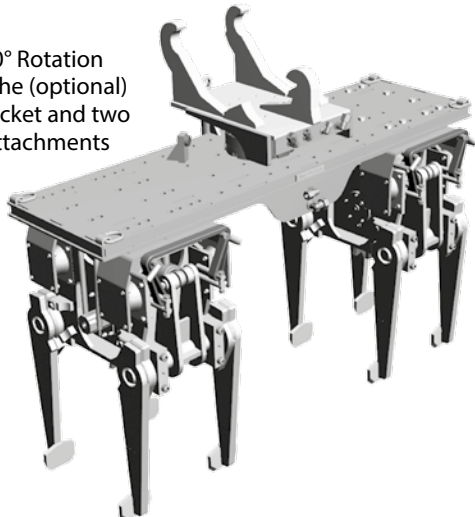

RST 0303
with two
Ballast Tamper
and S-Couplers

