

GAF

Fork Set

Lifting, moving and positioning of palletized or unpalletized materials is easy with the GAF Fork Set. Turn your excavator into a fork lift truck.

Suitable for excavators with 3 - 27 t/ 6600 - 59400 lbs operating weight.

- **High lifting capacity.**
- **Lightweight.**
- **Highly economical:** good value for money.
- **Adapted for being used with a tiltrotator:** best handling in this combination.
- **Mechanically adjustable forks.**
- **Easy to connect** by quick coupler adapter.
- **Wide range of quick coupling adapters:** S30 to S80 and/or B18 to B30.

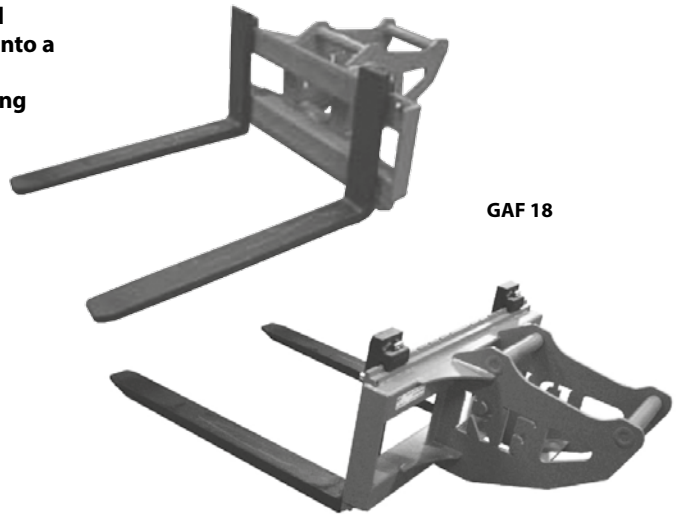

Fork Set

Type	max. Load capacity (kg / lbs)	Width (mm / in)	Self weight (kg / lbs)	Depth of fork (mm / in)	Operating weight (t / lbs)
GAF 6	1900 / 4180	1000 / 39.37	140 / 308	1400 / 55.12	3 - 6 / 6600 - 13200
GAF 8	1900 / 4180	1200 / 47.24	190 / 418	1400 / 55.12	6 - 8 / 13200 - 17600
GAF 12	2500 / 5500	1200 / 47.24	200 / 440	1400 / 55.12	9 - 12 / 19800 - 26400
GAF 18	4000 / 8800	1200 / 47.24	340 / 748	1400 / 55.12	13 - 18 / 28600 - 39600
GAF 20	4000 / 8800	1200 / 47.24	420 / 924	1400 / 55.12	19 - 20 / 41800 - 44000
GAF 24	5000 / 11000	1200 / 47.24	440 / 968	1400 / 55.12	21 - 27 / 46200 - 59400

Package consists of: mechanically adjustable fork, adapter for quick coupling system

Please note: put loads always the nearest to the back and to the centre of gravity

Requirements of Excavator

Different quick coupler systems available.  The excavator must be conform to lifting regulations.

Pictures

