

**PK 8501 / 9001 EH**

**PALFINGER**

LIFETIME EXCELLENCE

**WITH THE APPROPRIATE AUXILIARY EQUIPMENT, THIS CRANE BECOMES A MULTI-FUNCTIONAL WORK MACHINE**



# LIFETIME EXCELLENCE

**PALFINGER LOADER CRANES ARE CONVINCING DUE TO THEIR SUPERIOR LIFE-CYCLE PERFORMANCE. THEY ARE THE MOST ECONOMICAL AND ALSO THE MOST RELIABLE OVER THE ENTIRE PRODUCT LIFE. FROM SOLUTION FINDING TO RESALE.**

BETTER  
SOLUTIONS

BETTER  
EFFICIENCY

BETTER  
ERGONOMICS

HIGHER VALUE  
RETENTION



HIGHER  
AVAILABILITY

HIGHER  
SERVICEABILITY

BETTER  
ECOLOGY

MORE  
RELIABILITY





# EXCELLENT FOR THE MUNICIPAL SECTOR





- Maximum utilisation of the working range due to HPSC
- More lifting power due to E-HPLS
- High operator friendliness thanks to optional radio remote control
- High value retention due to KTL coating
- Higher payloads due to intelligent lightweight design





# FIRST-CLASS IN DESIGN AND PERFORMANCE

# 12 HIGHLIGHTS



**KNUCKLE JOINT ON KNUCKLE BOOM**  
MORE POWER ON THE HOOK

The knuckle joint significantly improves the crane's motion geometry



**LOW-MAINTENANCE EXTENSION SYSTEM**  
REDUCES SERVICE TIME

With sliding elements made of synthetic material and the high-quality KTL coating, this boom system significantly simplifies service performed by the operator. This saves time and money – and protects the environment.



**HIGH SPEED EXTENSION**  
FOR EFFICIENT ASSIGNMENTS

The High Speed Extension speeds up the extension boom system. Crane works faster and more efficiently.

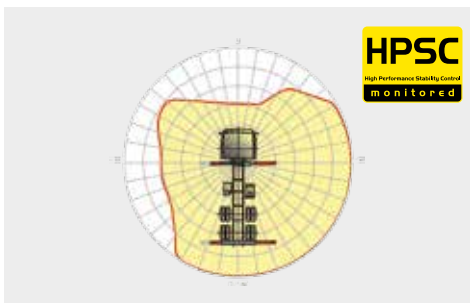

**HPSC**  
MAXIMUM UTILISATION OF THE WORKING RANGE

The variable stabiliser positioning of the High Performance Stability Control System makes it possible to utilise the lifting capacity to the maximum. It enables working within tight spaces.



**PAL 50**  
COMFORT AND SAFETY

The PALTRONIC 50, PALFINGER offers the latest control electronics for the series production crane. The custom designed electronic operates and monitors the crane and offers more efficiency in use and safety.



**CONTROL CONSOLE**  
ALL INFORMATION AT A GLANCE

All important information about the crane can be seen on the main control stand. A digital indicator counts and displays the operating hours. Ergonomic control levers and the optional lighting package provide increased safety and comfort even in poor visibility conditions.



**KTL – CATHODIC DIP PAINTING**  
FOR RETAINING HIGH VALUE

The UV-resistant coating guarantees long-term surface protection. Perfect appearance during the entire lifetime for maximum resale value.



**FUNCTIONAL DESIGN**  
PRACTICAL AND ATTRACTIVE

Robust plastic covers protect crane parts against dirt and damage. Better appearance and increased operational comfort – during the entire lifetime.



**RADIO REMOTE CONTROL**  
DIALOGUE WITH THE OPERATOR

PALFINGER radio remote controls are equipped with linear lever or cross lever and provide the greatest possible comfort for the operator. All EH models with LED-Display inform the crane operator about the different operating conditions.



**HOSE EQUIPMENT FOR ATTACHMENTS**  
VERSATILE AND USER-FRIENDLY

The hose equipment offers an easy means of connecting auxiliary equipment. The hose equipment is guided in hose trays for protection.

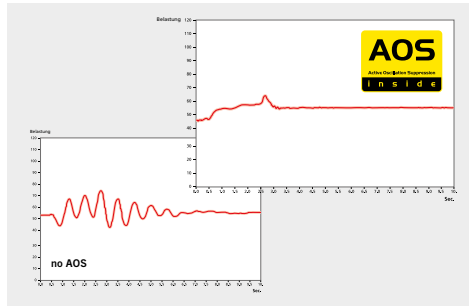

**AOS**  
MAXIMUM PRECISION AND SAFETY

The active oscillation suppression system prevents "post-oscillation" in the event of rapid braking or load changes. The stress peaks on the extension boom system are reduced and material fatigue and wear are minimised. This increases the resale value.



**LIGHTING PACKAGE\***  
MORE CRANE SAFETY PARTICULARLY AT DUSK AND DARK

LEDs which backlight the control panel make it easier to read off the crane functions and provide the crane operator with a quick overview of the entire panel during the working process. LED warning lights in the supporting cylinders mean greater safety for crane operator and passers-by.



\* Optional features / country-specific equipment

# PK 8501 HIGH PERFORMANCE

## STD

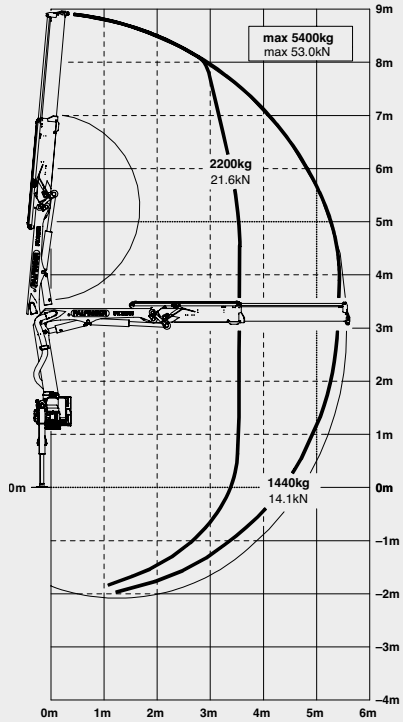

## A

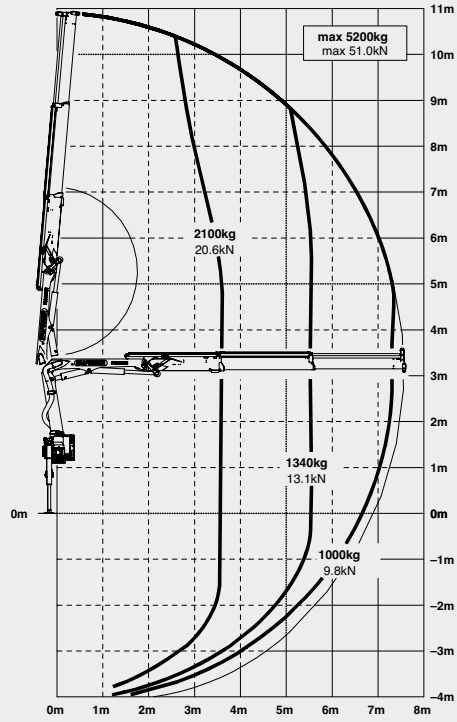

## C

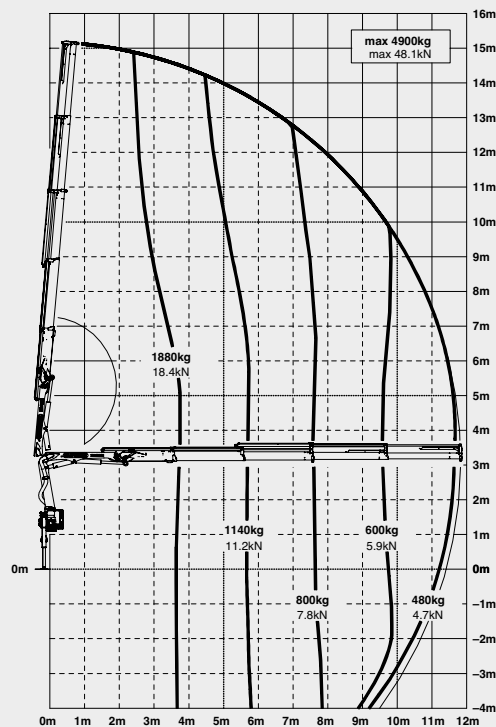

## D

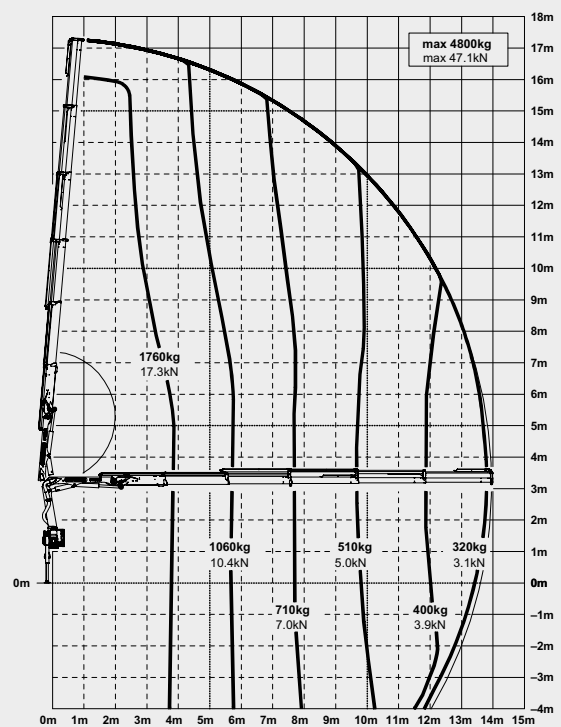



# PERFECT FOR DEMANDING ROUTINE WORK

**B**

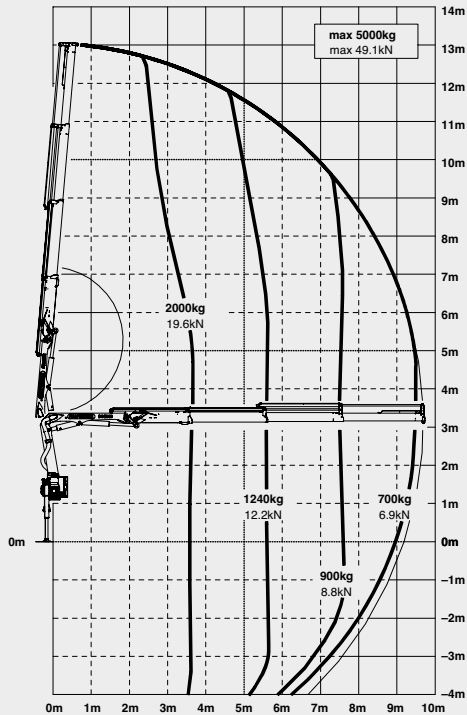

## LIFTING CAPACITIES

max.		5400 kg	11900 lbs
3.5 m	11' 6"	2200 kg	4850 lbs
5.4 m	17' 9"	1440 kg	3170 lbs

**A**

max.		5200 kg	11460 lbs
3.6 m	11' 10"	2100 kg	4630 lbs
5.5 m	18' 1"	1340 kg	2950 lbs
7.4 m	24' 3"	1000 kg	2200 lbs

**B**

max.		5000 kg	11020 lbs
3.7 m	12' 2"	2000 kg	4410 lbs
5.6 m	18' 4"	1240 kg	2730 lbs
7.5 m	24' 7"	900 kg	1980 lbs
9.5 m	31' 2"	700 kg	1540 lbs
11.7 m*	38' 5"	520 kg	1150 lbs
13.7 m*	44' 11"	410 kg	900 lbs

**C**

max.		4900 kg	10800 lbs
3.8 m	12' 6"	1880 kg	4140 lbs
5.7 m	18' 8"	1140 kg	2510 lbs
7.6 m	24' 11"	800 kg	1760 lbs
9.6 m	31' 6"	600 kg	1320 lbs
11.6 m	38' 1"	480 kg	1060 lbs
13.6 m*	44' 7"	380 kg	840 lbs
15.6 m*	51' 2"	300 kg	660 lbs

**D**

max.		4800 kg	10580 lbs
3.9 m	12' 10"	1760 kg	3880 lbs
5.8 m	19' 0"	1060 kg	2340 lbs
7.7 m	25' 3"	710 kg	1570 lbs
9.7 m	31' 10"	510 kg	1120 lbs
11.7 m	38' 5"	400 kg	880 lbs
13.7 m	44' 11"	320 kg	710 lbs
15.7 m*	51' 6"	260 kg	570 lbs

# PERFECT DIMENSIONS

## EXTENSION BOOM VARIATIONS

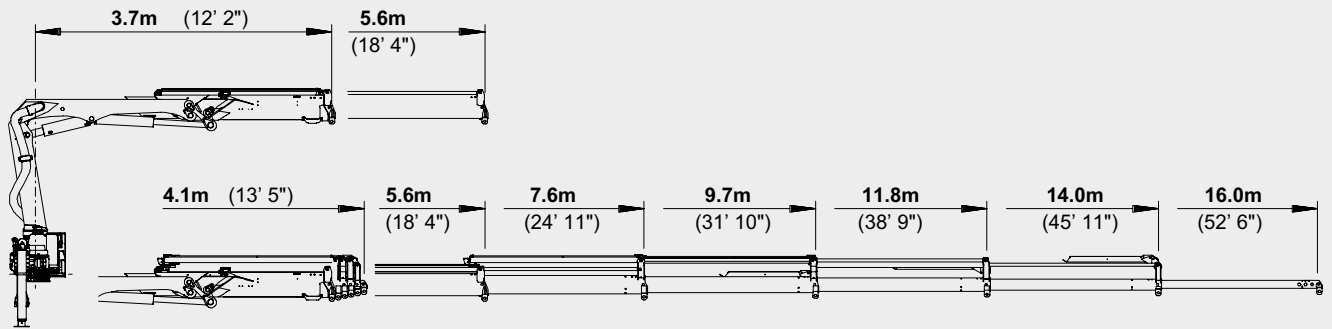

## DIMENSIONS

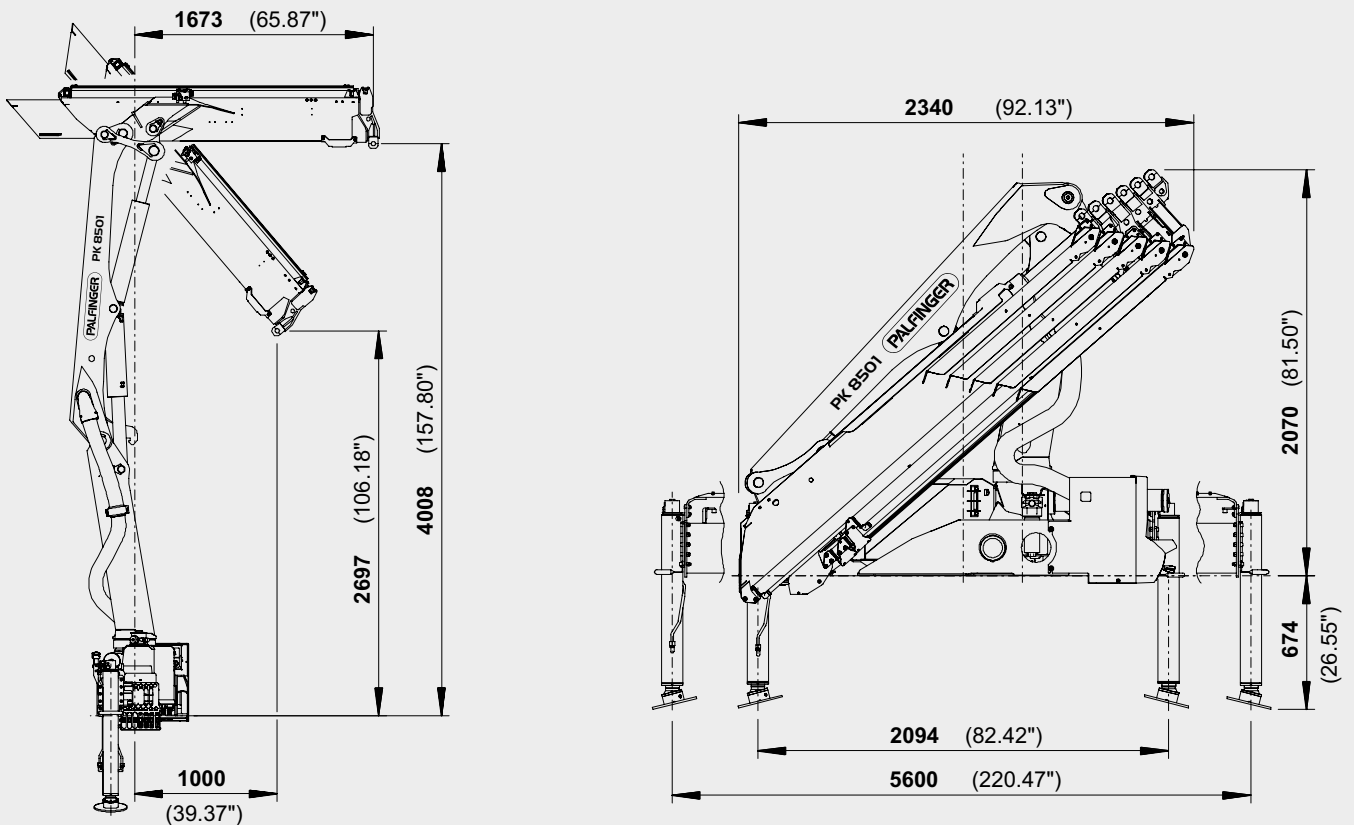

## PK 8501

### TECHNICAL SPECIFICATIONS (EN 12999 HC1 HD4/B3)

Max. lifting moment	7.8 mt/76.5 kNm	56440 ft.lbs
Max. lifting capacity	5700 kg/55.9 kN	12570 lbs
Max. hydraulic outreach	14.0 m	45' 11"
Max. manual outreach	16.0 m	52' 6"
Slewing angle	400°	
Slewing torque	1.0 mt/9.8 kNm	7240 ft.lbs
Stabiliser spread (std./max.)	3.2 m / 5.6 m	10' 6" / 18' 4"
Fitting space required (std.)	0.69 m	2' 3"
Width folded	2.32 m	7' 7"
Max. operating pressure	320 bar	4640 psi
Recommended pump capacity	from 25 l/min to 35 l/min	6.6 US gal./min 9.2 US gal./min
Dead weight (std.)	1022 kg	2250 lbs

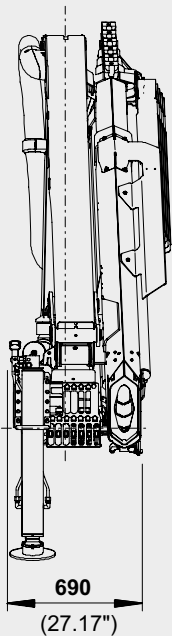



# PK 9001 EH HIGH PERFORMANCE

STD

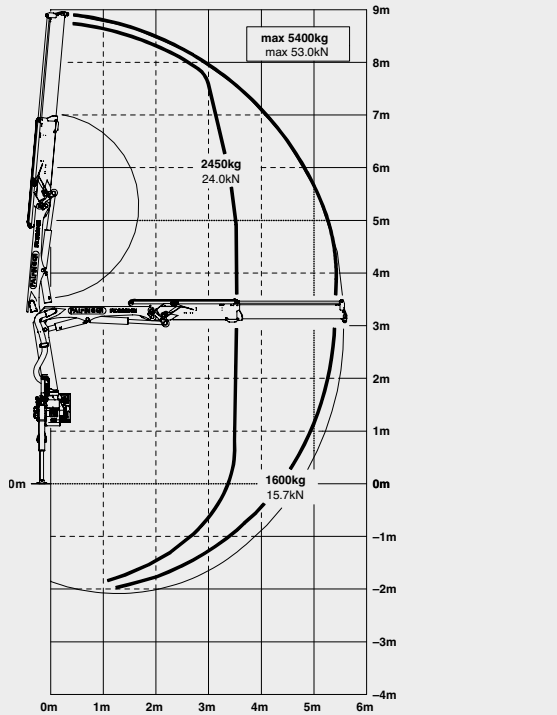

A

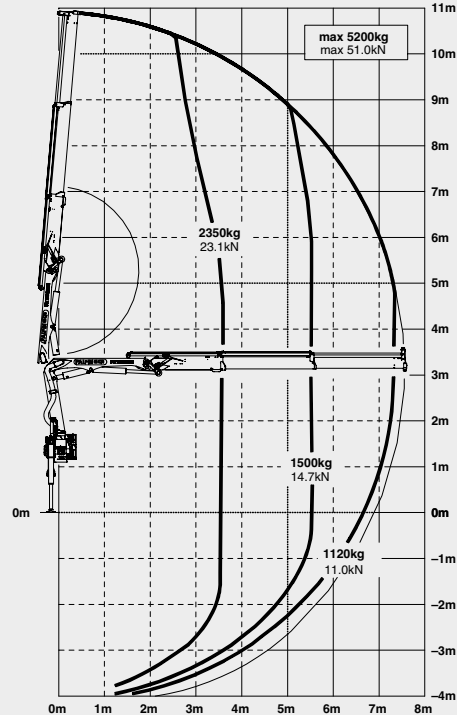

C

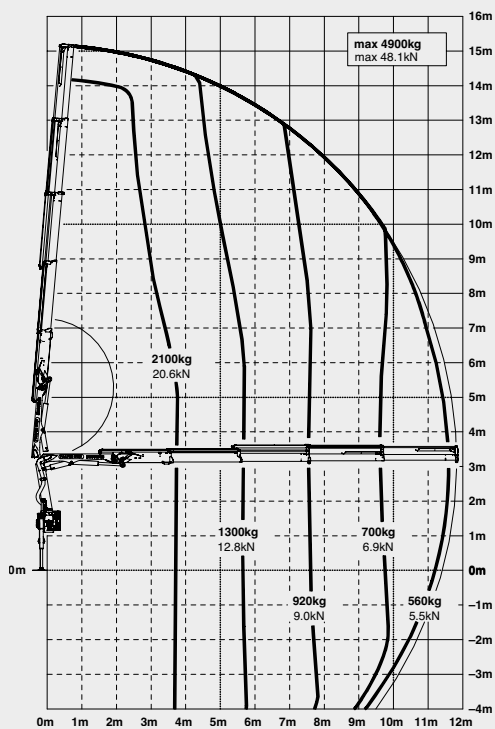

D

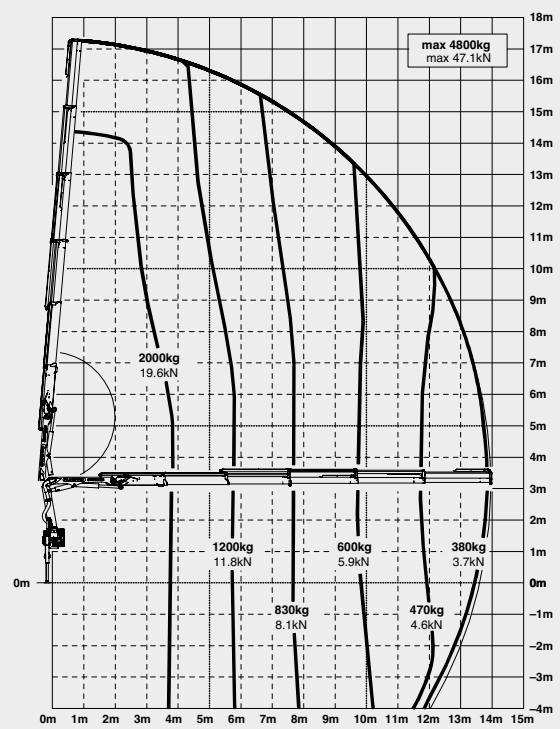

# VERSATILITY SETS NEW STANDARDS

**B**

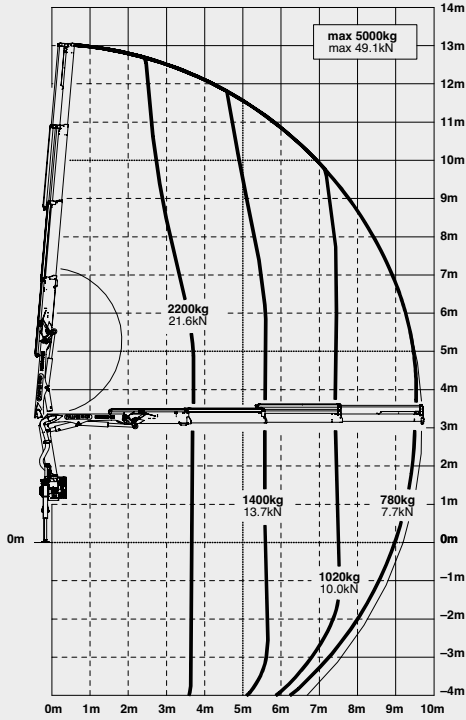

## LIFTING CAPACITIES

max.		<b>5400 kg</b>	<b>11900 lbs</b>
3.5 m	11' 6"	2450 kg	5400 lbs
5.4 m	17' 9"	1600 kg	3530 lbs

**A**

max.		<b>5200 kg</b>	<b>11460 lbs</b>
3.6 m	11' 10"	2350 kg	5180 lbs
5.5 m	18' 1"	1500 kg	3310 lbs
7.4 m	24' 3"	1120 kg	2470 lbs

**B**

max.		<b>5000 kg</b>	<b>11020 lbs</b>
3.7 m	12' 2"	2200 kg	4850 lbs
5.6 m	18' 4"	1400 kg	3090 lbs
7.5 m	24' 7"	1020 kg	2250 lbs
9.5 m	31' 2"	780 kg	1720 lbs
11.7 m*	38' 5"	600 kg	1320 lbs
13.7 m*	44' 11"	470 kg	1040 lbs

**C**

max.		<b>4900 kg</b>	<b>10800 lbs</b>
3.8 m	12' 6"	2100 kg	4630 lbs
5.7 m	18' 8"	1300 kg	2870 lbs
7.6 m	24' 11"	920 kg	2030 lbs
9.6 m	31' 6"	700 kg	1540 lbs
11.6 m	38' 1"	560 kg	1230 lbs
13.6 m*	44' 7"	440 kg	970 lbs
15.6 m*	51' 2"	350 kg	770 lbs

**D**

max.		<b>4800 kg</b>	<b>10580 lbs</b>
3.9 m	12' 10"	2000 kg	4410 lbs
5.8 m	19' 0"	1200 kg	2650 lbs
7.7 m	25' 3"	830 kg	1830 lbs
9.7 m	31' 10"	600 kg	1320 lbs
11.7 m	38' 5"	470 kg	1040 lbs
13.7 m	44' 11"	380 kg	840 lbs
15.7 m*	51' 6"	300 kg	660 lbs

\*mechanical extension

# PERFECT DIMENSIONS

## EXTENSION BOOM VARIATIONS

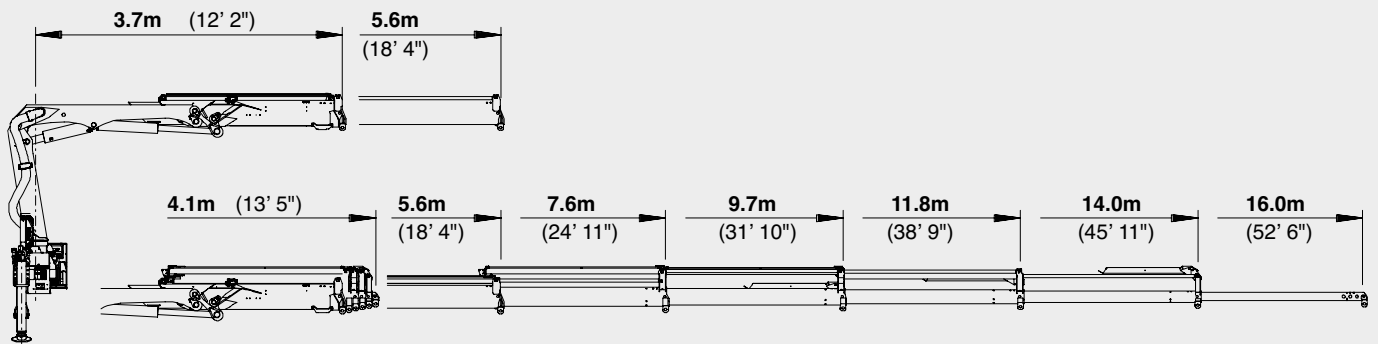

## DIMENSIONS

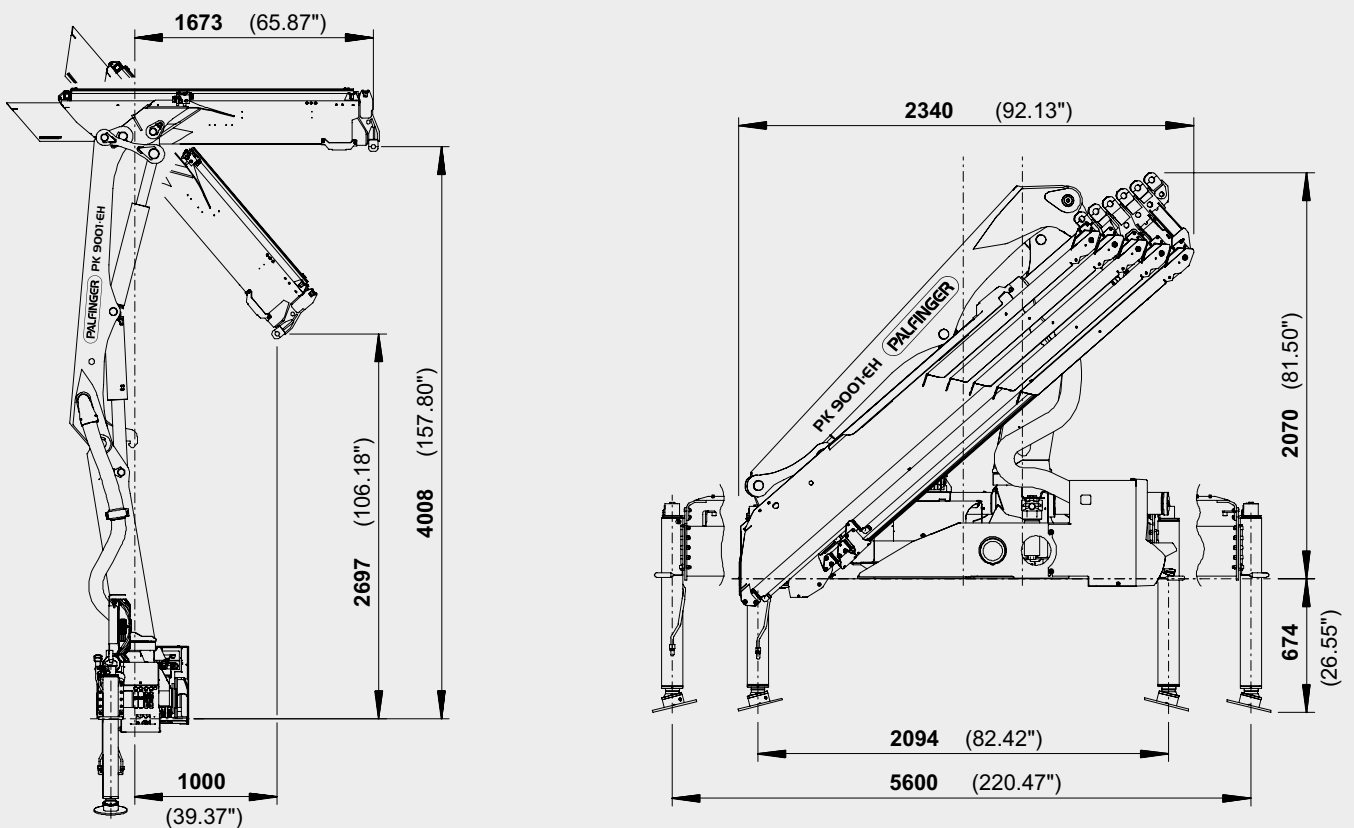



## PK 9001 EH

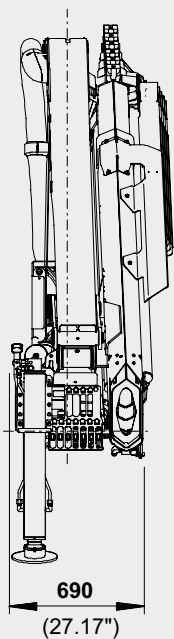

## TECHNICAL SPECIFICATIONS (EN 12999 HC1 HD4/B3)

Max. lifting moment	8.7 mt/85.3 kNm	62950 ft.lbs
Max. lifting capacity	5700 kg/55.9 kN	12570 lbs
Max. hydraulic outreach	14.0 m	45' 11"
Max. manual outreach	16.0 m	52' 6"
Slewing angle	400°	
Slewing torque	1.0 mt/9.8 kNm	7240 ft.lbs
Stabiliser spread (std./max.)	3.2 m / 5.6 m	10' 6" / 18' 4"
Fitting space required (std.)	0.69 m	2' 3"
Width folded	2.32 m	7' 7"
Max. operating pressure	350 bar	5075 psi
Recommended pump capacity	from 40 l/min to 50 l/min	10.6 US gal./min 13.2 US gal./min
Dead weight (std.)	1047 kg	2310 lbs

## PACKAGE MODEL

- E-HPLS
- Paltronic 50
- Radio remote control with LED display
- Danfoss control valve or PVG2000
- 8.5 kW oil cooler
- 100 l oil tank



Cranes shown in the leaflet are partially optional equipped and do not always correspond to the standard version. Country-specific regulations must be observed. Dimensions may vary. Subject to technical changes, errors and translation mistakes.